

# GATOR UTILITY VEHICLES



**JOHN DEERE**

NOTHING RUNS LIKE A DEERE





## CONTENTS

Work. Done Well. ....	4–5
All-round Support .....	6–9

## WORK UTILITY VEHICLES

Features .....	12–15
Gator TS .....	16–17
Gator TX & TX Turf .....	18–19
Gator TE .....	20–21
Gator TH 6x4 .....	22–23
Gator HPX815E .....	24–25

## CROSS-OVER VEHICLES

Features XUV500 Series .....	28–29
Gator XUV560E .....	30–33
Gator XUV590M .....	34–35
Gator XUV590M S4 .....	36–37
Features XUV855M & XUV855M S4 .....	38–39
Gator XUV855M .....	40–41
Gator XUV855M S4 .....	42–43
Features XUV835M, XUV865M & XUV865R ....	44–47
Gator XUV835M .....	48–49
Gator XUV865M .....	48–49
Gator XUV865R .....	50–51

<b>ATTACHMENTS</b> .....	52–67
--------------------------	-------

<b>PRODUCT SPECIFICATIONS</b> .....	68–71
-------------------------------------	-------



# WORK DONE WELL.

»*WORK. DONE WELL.*«

Every day, you give the job your best. As a true professional and craftsman, you go the extra mile to get the best results you can. Not because the client expects it, or your company. But because you'd never settle for anything less yourself.

That same mentality explains why you appreciate having a strong and able partner by your side to help shoulder the load. Like any good worker, you know from experience that 'quality in' and 'quality out' really do go hand-in-hand.

If that sounds like you, you're in good company with John Deere. We take as much pride in the quality of our utility vehicles as the people who use them all over the world. Professionals like you, who understand the meaning of work done well.



# ALL-ROUND SUPPORT

From advice and sales to maintenance and repairs, your local John Deere partner has everything you need to keep your investment running like clockwork. Find your nearest John Deere dealer today at [dealerlocator.deere.com](https://dealerlocator.deere.com)





## A GLOBAL COMMUNITY

The people at your local John Deere dealership are always there for you – with personal service you can rely on. As part of the John Deere community, they combine their own individual style with all the benefits of a strong global company.



## TAILOR-MADE FINANCING

John Deere Financial has been helping customers grow their businesses for more than 150 years. Based on our unique understanding of your market and the challenges you face, we offer competitive, tailor-made financing for the machines you need to raise your game.

From hire purchase to leasing and rentals, your local John Deere dealer can help you choose the options that suit your business best. Why not drop in for a chat?



# POWERGARD

STATUS: PROTECTED

When you protect your equipment with a PowerGard Protection plan\*, your business has the steady machine uptime and nonstop peak performance it needs to thrive.



PowerGard agreements protect you against unexpected repair costs and keep your maintenance on track with genuine parts. Three fixed rate packages provide increasingly comprehensive levels of cover to keep your machine running at peak performance with steady uptime.

## POWERGARD PROTECTION PLAN

Preventative maintenance work – it's essential for keeping equipment in good working order based on factory recommended intervals.\*

## POWERGARD PROTECTION

Base level of protection that covers unusual events that can lead to costly repairs, and also covers the main drive train components.

## POWERGARD PROTECTION PLUS

The ultimate in protection – the total peace of mind package that covers all components included in PowerGard Protection, plus electrical, cooling, hydraulics and more.

## FINANCING

Include your PowerGard Protection agreements into your financing offer and benefit from competitive rates, with flexible payments.\*\*

\*At participating dealers only. Requires a maintenance plan.  
\*\*At participating dealers only.





## FACTS, NOT GUESSWORK

Ever wished you could X-ray your machine to see how it's doing inside? Expert Check is the next best thing: a thorough diagnosis of all key components (including sensors, electronics and software) using up-to-the-minute, field-based checklists and tools that are exclusive to John Deere dealers. The result is a detailed report stating exactly where your machine stands, as well as what needs doing and when.

## CLEAR PRICES

Based on this report, you can tell us exactly what work you want done. With transparent pricing and all-in packages for parts and labour, Expert Check takes the guesswork out of repairs and maintenance, too.



## ORIGINAL JOHN DEERE PARTS

Even John Deere machines need repairs eventually. When the day comes, our dealers pull out all the stops to maximize uptime and get them back on the job. With a state-of-the-art workshop and a fully-trained technical team on hand, they can provide professional support backed by the latest updates coming direct from the factory. For smaller repairs you'd rather do yourself, they can supply everything you need overnight – even for older models.



# WORK UTILITY VEHICLES

THE VERSATILE WORKHORSE AT YOUR SIDE



Looking for a capable partner that treads softly, yet works as hard as you do? Put a Gator on your team – and relax.



# FEATURES

## WORK UTILITY VEHICLES

Added for your convenience. These Gator work utility vehicles are built tough and will assist you in your daily tasks. They work hard and come equipped with a host of features designed to help you get the job done as quickly and easily as possible.



### EFFECTIVE BRAKES

Every brake system is precisely matched to the vehicle load capacity. If you start with it in the back you can stop with it in the back.



### INTUITIVE CONTROLS

Even if you've never driven a Gator before, you'll feel at home right away. All the controls are simple, clear... and right where you need them.

### MORE OPERATING CONVENIENCE ON BOARD

Once you get behind the wheel of your work utility vehicle, you'll find even more convenient operating features and storage options on board. All models feature a park brake indicator light, hour meter, and tank-mounted fuel gauge as standard equipment. There's a glove box in the dash, plus additional storage and a hand-operated traction assist (differential lock) conveniently located between the seats. The Gator TH 6x4 comes with a traction assist indicator light, too.





## **HIGH FLOTATION TYRES**

All T-Series Gator Utility Vehicles come with top quality high flotation tyres that let you work hard without damaging the turf. With their special tread pattern, they're equally suitable on hard or soft surfaces.



## SPACIOUS AND DURABLE DELUXE CARGO BOX

The deluxe cargo box consists of a 15% glass-filled polypropylene composite material that eliminates rust, dents, and reduces noise. The cargo box floor and load guard (front panel) are made of steel.



**Deluxe Cargo Box Tilt:** With its integrated handle design and gas assist, the deluxe cargo box is now easier to latch, unlatch, raise, and lower. A prop rod is provided to hold the box in the upright position and limit its pivot travel.



**Integrated Tie-Down Points:** The deluxe cargo box offers several tie-down points for increased versatility: four corners inside the cargo box bed, four points on the load guard directly behind the operator station, tie-down bars on either side of the cargo box as well as six points on the underside of the cargo box frame.

**Deluxe Cargo Box Tailgate:** The improved tailgate allows for easy loading and unloading, features truck-like performance and can be operated with one hand. It can be opened or removed for easier clean-out or to accommodate longer items. The standard installed lanyards can also be removed to lower the tailgate to 150 degrees.



### FROM CARGO BOX TO FLAT BED

The improved deluxe cargo box offers even more versatility. When you need to load larger cargo, it easily converts to a convenient flat bed. This allows you to adapt your vehicle's loading space according to your needs, while the flat bed's load height enables easy loading and unloading.

Caution: Carrying extra long cargo that extends beyond the box can adversely affect your vehicle's overall stability.



***“MY GATOR IS  
MY BABY! IT’S  
COMFORTABLE  
AND SAFE, AND  
IT TAKES ME  
EVERYWHERE  
I NEED TO GO.”***

NUNO FAVINHA

**WORK**  
DONE WELL.



Nuno Favinha is the Irrigation Manager for three prestigious courses at Quinta do Lago, Portugal. The climate is dry, the challenges are complex and there’s no room for failure. “We have 120 ha of grass, six pump stations and miles of pipes and wiring so I’m always on the go.” Nuno’s Gator takes him everywhere, and he clearly loves it to bits. “Some day, when I have my farm, I want a Gator of my own.” ■

»WORK. DONE WELL.«

# GATOR TS

## CONSIDER IT DONE

Let your Gator TS take the strain. With its 401 cc petrol-powered engine and rugged build, this utility vehicle has a surprisingly light footprint on your turf: only 7.5 psi, less than a human footprint. The Gator TS combines heightened stability, impressive capacity, intuitive operation and plenty more features you can rely on.



### BUILT FOR HEAVY HAULING

Hauling heavy or bulky cargo comes easy with a strong 16-gauge cargo box. The box is located directly above the rear wheels for excellent stability. And, with a load height of 25 in (63.5 cm) you can make full use of its 227 kg cargo capacity. The cargo box can be manually tilted up to allow access to the drive system or assist in cleaning out the box, while a prop rod and extra tie-downs provide added operator convenience and safety. The tailgate can be opened or removed for clean-out or transport of longer items.

Caution: Carrying extra long cargo that extends beyond the box can adversely affect your vehicle's overall stability.



### OPERATE IN COMFORT

The Gator TS is a comfortable ride. It offers side-by-side bucket seating for one operator and one passenger plus the choice of an adjustable driver's seat attachment. Both seats tilt forward for dry storage and added convenience. The vehicle's smooth engine and intuitive controls make driving a pleasure.







## AT YOUR SERVICE

The control location and walk-through platform provide easy entry/exit for all, while additional hip restraints help keep you in your seats over rough terrain. The Gator TS also features an hour meter to assist in maintaining regular service intervals, a 12-V outlet (VDC) located on the instrument panel and integrated cupholders.

## TS

Petrol Engine
Displacement: 401 cc
Speed: 32 km/h
Rear Suspension: Two High-Flotation Tyres, Low Pressure Tyres (Solid Axle)
Towing Capacity: 408 kg
Cargo Capacity: 227 kg

- Comfortable Low Load Height
- Low Centre of Gravity

# GATOR TX & TX TURF

WORK HARD, TREAD SOFTLY

Gently does it. Our hard-working Gator TX models have all the power and capacity you need to get the job done quickly, safely and quietly.



## GATOR TX & TX TURF

Both models have flotation turf tyres and a payload capacity of 454 kg. The TX has a powerful 675 cc engine, while the TX Turf has 401 cc. Its stop-start technology, quiet operation and fuel-saving attributes make the TX Turf ideal for use in a Golf & Sports environment. The TX does not feature this technology.

## FLOTATION TURF TYRES & REDUCED SCUFFING

The Gator TX models are specifically engineered to tread softly. Differential design reduces scuffing of the turf during turns by ensuring that the inside wheels turn slower than the outside wheels. Traction assist (differential lock) is built into the transaxle, which allows locking the rear drive wheels together and provides increased traction where needed.



**Flat Bed:** Cargo box sides can be removed in minutes to convert the box to a flat bed.



## Cargo Box Side

**Extension:** Increase your cargo box's side height and volume to haul twice the amount. The tailgate pivots at the top for easier access.



### STABLE DESIGN

With their low centre of gravity the Gator TX models provide excellent stability on hilly, uneven terrain. For balanced weight distribution the cargo-box is centred over the rear wheels.

### ON ALL TX & TX TURF MODELS

- Rear Suspension: Semi-Independent Coil-Over-Shock
- Towing Capacity: 454 kg
- Cargo Capacity: 272 kg
  
- Low Centre of Gravity
- Deluxe Cargo Box
- All-Wheel Disc Brakes



**Tailgate:** Fold out the pickup-style tailgate to 90 degrees and down a full 150 degrees with just one hand.



### TX

Petrol Engine
Displacement: 675 cc
Speed: 32 km/h



### TX TURF

Petrol Engine
Displacement: 401 cc
Speed: 25 km/h

- Foot Pedal Start

# GATOR TE

A ZERO-EMISSIONS GATOR THAT JUST KEEPS GOING

Golf courses, work premises, enclosed spaces . . . When quiet operation and zero emissions are the order of the day, the Gator TE really delivers. And thanks to an impressive combination of driving and utility features, you can go electric without compromising on power or functionality.



## WHISPER-QUIET ELECTRIC POWER

The Gator TE is equipped with a motor-powered 48-V electrical system for faster acceleration and better uphill performance. Dynamic braking and anti-rollback offer additional security when you take your foot off the accelerator, preventing the vehicle from freewheeling when stopped on a grade. Overspeed control to approximately 13 km/h (8 mph) and the electronic brake ensure your speed remains constant without the loss of torque, even on a downhill incline or in reverse. With its eight high-capacity batteries, the Gator TE can work hard for 7–8 hours between charges – all with zero emissions and practically no noise.

Energy is transformed back into the batteries when the vehicle exceeds the set maximum speed or when dynamic braking is engaged. That's an estimated 3–5% of regenerative energy for a day of work.





**Hard Worker:** Don't be deceived by the quiet exterior of the Gator TE Utility Vehicle. With solid, one-piece forged axles, a cast aluminium rear axle housing and a deluxe cargo box, it's built for hard work in all conditions.

### INCREASED RUN-TIME

Every unit comes with an Underwriters Laboratories Inc. (UL) approved on-board charger that lets you to charge your vehicle from anywhere. Additional safety features prevent overcharging or driving while connected to the charger. Its advanced temperature sensor technology improves the information flow coming in and out of the charger and allows the batteries to charge more fully. This can increase run time by up to 75%, depending on your usage.



### TE

Electric Engine
Speed: 24 km/h
Rear Suspension: Two High-Flotation Tyres, Low Pressure Tyres (Solid Axle)
Towing Capacity: 273 kg
Cargo Capacity: 227 kg

- Super-Quiet Electric Operation
- Zero Emissions

# GATOR TH 6X4

TOW MORE THAN YOU THOUGHT

With six wheels, a low centre of gravity and power to spare, the Gator TH 6x4 makes light work of heavy loads. It's our strongest workhorse, can transport up to 508 kg and is prepared to help you power through.



## FULL POWER AHEAD

The powerful yet economical 854 cc, three-cylinder, liquid-cooled, four-cycle diesel engine makes the Gator TH 6x4 a speedy mover even when the going gets tough. The engine is rated 13.6 kW (18.5 hp) at 3400 rpm using standard ECE-R24. Its overhead valve was designed for greater efficiency and fuel economy. It contains a dry replaceable single-element air cleaner with remote intake as well as a spark-arresting muffler. Indirect injection diesel with glow plugs ensure fast starts in cold temperatures, while its dual radiator system adds cooling capacity.



## GOLF PRO

With six high-flotation wheels, the Gator TH 6x4 travels lightly over your valuable turf.





## HEAVYWEIGHT CHAMPION

With a total towing capacity of 726 kg (including passengers), the Gator TH 6x4 is the strongest workhorse in the T-series family. See page 68–69.



## TH 6X4

Diesel Engine
Displacement: 854 cc
Speed: 32 km/h
4-Wheel Drive
Rear Suspension: Two High-Flotation Tyres, Low Pressure Tyres (Solid Axle)
Towing Capacity: 726 kg
Cargo Capacity: 508 kg

– Low Load Height

# GATOR HPX815E

## READY FOR WORK

Love a challenge? So does the Gator HPX815E. Even when fully loaded, this utility vehicle is built to clear all types of ground. Its 635 kg payload capacity, 4-wheel drive and semi-independent suspension will help you go where others can't.



### HIGH-STRENGTH HYDRO-FORMED STEEL FRAME

Our hydro-formed frames have fewer welded or bolted joints for maximum durability, plus high tolerances for twisting and heavy loads.

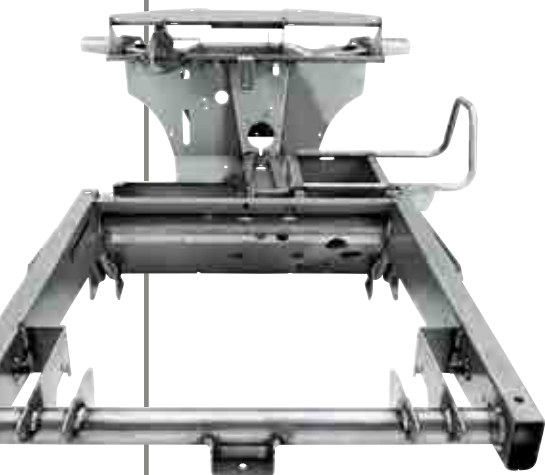

### PILE IT ON

Heavy loads? No problem, thanks to a cargo capacity of 454 kg.





**Safety First:** Each vehicle is fitted with a ROPS (Roll Over Protection Structure) canopy and comfortable three-point seat belts to keep you safe at all times.



## HPX815E

Diesel Engine
Displacement: 854 cc
Speed: 40 km/h
4-Wheel Drive
Rear Suspension: Coil-Over-Shock
Towing Capacity: 590 kg
Cargo Capacity: 454 kg

- High-Strength Hydro-Formed Steel Frame
- Standard Deluxe ROPS Canopy
- Road Homologation\*

\* Homologation type may vary by country. Please refer to your dealer.



**Stop On A Sixpence:** Fully hydraulic brakes ensure first-class braking performance.

# CROSS-OVER VEHICLES

A BREED APART



Experience the ultimate freedom in a Gator XUV! Off road or on, these working vehicles are a dream to drive – and fully equipped for safe, surefooted productivity.



# FEATURES

## XUV500 SERIES – CROSS-OVER VEHICLES

When your work involves moving people and cargo across rough terrain in all weather, consider a Gator XUV. These sure-footed workhorses combine outstanding performance with all the pulling power, versatility and operating comfort you demand from a hard-working professional vehicle.



### ALL-DAY COMFORT

Our operator-centric design combines true comfort with superb convenience. This includes easy entry/exit and pass through for the operator and passenger, optimal seating positions for more legroom, and automotive-like ergonomics for excellent driving comfort. Forward-tilting seats and 34 L of sealed storage keep you and your belongings dry when it rains, while the built-in 12-V electrical outlet ensures you always have power for your accessories.



### SMOOTH RIDE AND EXCELLENT HANDLING

The XUV560E and XUV590M are equipped with four-wheel independent suspension. This technology provides unique suspension on challenging terrain and excellent handling of corners so that you can operate in comfort.

The front suspension enables optimal front-wheel control, precise steering, maximum ground clearance, and wheel extension for superior traction and vehicle control across the most demanding terrain.



## LARGE AND EXTRA-DURABLE CARGO BOX



**Smooth Tilt, Load Removal And Tie-Down:** The easy-to-use, one-piece cargo box is critical to performing tasks quickly and efficiently. To remove content from the cargo box, simply tilt the truck-style tailgate in one smooth motion. The manual release also functions as the lift lever and can be operated from both sides of the vehicle. To reduce overall lift effort, we placed the box's pivot point closer to centre. The durable cargo box offers integrated tie-down points for increased versatility. Find flip-up D-shaped rings in all four corners inside the cargo box bed as well as multiple points along the edge of its side walls.

**Convenient Tailgate:** The truck-like tailgate can be opened or removed tool-free for easier clean-out or transport of longer items. Its pivot point is made of hardened steel for added durability. The standard lanyards can easily be disconnected to further convenience loading and unloading.



# GATOR XUV560E

## YOUR RELIABLE JACK OF ALL TRADES

Whatever it is, this heavy-duty workhorse is there to help you get the job done. Despite it being one of our smallest cross-over utility vehicles, the reliable Gator XUV560E provides all the versatility you can get.



### SLEEK YET HARD-WORKING

With a modern front fascia, wide front bumper, sweeping hood lines and high fender lines, this utility vehicle is quite the looker. Yet it is equally hard-working, capable off-road and very easy to drive. For instance, the steel front bumper supports the styled front composite parts, while the heavy steel skid plate provides extra protection from rocks and slumps. Its sweeping headlights offer mounting locations for a turn signal light kit.



### FULLY INDEPENDENT SUSPENSION

Sets the standard for comfort and provides superior terrain capability while maintaining traction through all conditions.



## **QUICK ACCELERATION**

In line with its appearance the Gator XUV560E is literally up to speed. Powered by a 570 cc V-twin gasoline engine, you can expect swift acceleration and a top speed of 45 km/h (29 mph). The powerful engine is poised to deliver acceleration in 3.5 seconds. Its carburetor is tuned for rapid throttle response, reliable cold-weather starting, smooth mid-range power delivery and quiet idling. That way, you'll not only get the job done well, you'll get it done quickly.



## EASY DOES IT

The cargo box consists of a high-density polyethylene copolymer composite material that eliminates rust and dents, and also reduces noise. It matches up well with the truck-style tailgate that can easily be opened or removed when necessary and operated with one hand. The tailgate folds down 90°, making it even easier on you and your back to load and offload.



## OPERATOR COMFORT

The car-style dashboard, foot pedal parking brake and ample storage capacity make the XUV560E a pleasure to drive.



## FULLY ENCLOSED CVT TRANSMISSION

High engine and CVT air intake positions help to keep water and debris out and prevent overheating.



## XUV560E

Petrol Engine
Displacement: 570 cc
Speed: 45 km/h
4-Wheel Drive
Fully Independent Suspension
Towing Capacity: 499 kg
Cargo Capacity: 181 kg

– Road Homologation\*

\* Homologation type may vary by country.  
Please refer to your dealer.





**“THE GATOR  
IS A REAL  
WORKHORSE.  
I USE IT FOR  
EVERYTHING AND  
IT’S NEVER ONCE  
LET ME DOWN.”**

**WORK  
DONE WELL.**

»**WORK. DONE WELL.**«



Will Harris has two favourites on the farm, and they couldn't be more different. "My Gator is completely reliable. It never complains and always does exactly what I want", he smiles. "My donkey, not so much." ■

# GATOR XUV590M

IT. DOES. EVERYTHING.

Even with a full payload, this mid-range XUV is a true all-rounder that combines high transport speeds and power steering with superb ride comfort and handling – even on challenging terrain.



## QUICK ACCELERATION

The Gator XUV590M Cross-Over Series relies on a 586 cc (35.8 cu in) inline-twin-cylinder electronic fuel injected (EFI) gasoline engine to reach a top speed of 60 km/h (37 mph). An electronic control unit (ECU) ensures optimal engine performance. The engine is liquid-cooled and rated 31 hp\* at 5200 rpm.

\* The engine horsepower information is provided by the engine manufacturer to be used for comparison purposes only. The actual operating horsepower will be less.



## QUALITY RIDE

Enjoy smooth, comfortable handling thanks to power steering, 4-wheel drive and fully independent suspension.



## FUNCTIONAL DASH

See 18 functions at a glance – from speed and rpm to fuel, temp and diagnostics.





### POWER TO SPARE

Even on a 20% gradient, the 31 hp engine maintains its top speed of 60 km/h.



### XUV590M

Petrol Engine
Displacement: 586 cc
Speed: 60 km/h
4-Wheel Drive
Fully Independent Suspension
Power Steering: Standard
Towing Capacity: 499 kg
Cargo Capacity: 181 kg

– Road Homologation\*

\* Homologation type may vary by country. Please refer to your dealer.



### STURDY AND SAFE

The heavy-duty suspension, wheels and tyres are built for years of hard work.



### HALF DOORS

These rugged poly half doors keep you safe without restricting your vision.

# GATOR XUV590M S4

FOUR SEATS, FOUR SMILES

Even with four people on board, power steering makes driving the Gator XUV590M S4 effortless. The rear bench folds down in seconds to fit longer items or more equipment, making this cross-over utility vehicle amazingly flexible.



## CARRY EVEN MORE

The cargo box comes equipped with 20 tie-down points and carries 181 kg. Also, the tailgate and rear bench easily fold down to make room for more.



## QUICK ACCELERATION

Just like its two-seater counterpart, the Gator XUV590M S4 is powered by a 586 cc (35.8 cu in) inline-twin-cylinder electronic fuel injected (EFI), liquid-cooled and electronically controlled (ECU) gasoline engine. With an impressive 31 hp\* at 5200 rpm, this workhorse has the ability to reach 60 km/h (37 mph) top speed and will reliably transport you, up to three other passengers and more across all sorts of terrain.

\* The engine horsepower information is provided by the engine manufacturer to be used for comparison purposes only. The actual operating horsepower will be less.





### FUNCTIONAL DASH

Read 18 functions at a glance on the brightly-lit digital display.



### XUV590M S4

Petrol Engine
Displacement: 586 cc
Speed: 60 km/h
4-Wheel Drive
Fully Independent Suspension
Power Steering: Standard
Towing Capacity: 499 kg
Cargo Capacity: 181 kg

– Road Homologation\*

\* Homologation type may vary by country. Please refer to your dealer.



### FULLY INDEPENDENT SUSPENSION

Power steering, 4-wheel drive and fully independent suspension that adjusts to your payload make driving this cross-over utility vehicle a real treat. An additional sway bar on the rear axle lets you and your front/rear passengers travel in comfort, even in extreme conditions.

# FEATURES

## XUV855M & XUV855M S4 – CROSS-OVER VEHICLES

When you work hard all day, you need a vehicle that can keep up. The moment you climb aboard the diesel-powered XUV855M or the XUV855M S4 you will know that you have found an ideal partner to manage heavy loads and tricky terrain.



### **PERFORMANCE- ENHANCING SUSPENSION & TRACTION**

Take rugged terrain and gradients in stride with these high-performance, 4-wheel drive utility vehicles. Dual A-arm front and rear suspension features 203.2 mm (8 in) of travel to provide ample compression and wheel extension, making for a smooth ride and excellent hauling characteristics. The entire suspension system has been optimized to handle all payloads, from zero to maximum, without compromising ride quality or vehicle stability. An additional solid antiroll bar with fully rubber-isolated connecting links and pivots limits body roll and enables quiet operation. This keeps all four wheels on the ground for optimal traction and vehicle control.





### **ALL-OUT DIESEL POWER**

The XUV855M and XUV855M S4 cross-over vehicles derive their power from an advanced diesel engine that provides several operational benefits, including superb starting, idling and throttle response. Rated 16.1 kW (21.9 hp) at 3400 rpm using standard ECE-R24, the engine operates quietly across the entire rpm range.



# GATOR XUV855M

POWER YOUR WAY THROUGH EVEN THE BIGGEST JOBS

With the Gator XUV855M at your side, no job seems too hard to handle. This powerful cross-over utility is built to pull through and make it feel easy. Rest assured, this one is a keeper.



## WORKS AS HARD AS YOU DO

The Gator XUV855M is a notorious hard worker, with a rugged design and total payload of 635 kg. Its cargo box consists of a noise-reducing, high-density polyethylene copolymer composite material that eliminates rust and dents. The truck-like tailgate can be operated with one hand. It can also be opened or removed for easier clean-out or to accommodate longer items.



## QUALITY TIME

Operator-centric design and automotive-like ergonomics make for a comfortable ride, while its on-road performance is so good, you'll always arrive with a smile. The XUV855M also features easy entry/exit and pass through for both the operator and the passenger as well as optimal seating positions for more legroom – you'll wish the journey was longer.







## STOP AT NOTHING

With the XUV855M and its on-demand 4-wheel drive at your side, you can power through demanding terrain with confidence. It comes equipped with four-wheel independent suspension to complement its comfortable operation station. This unique set-up ensures a smooth ride over rough spots and excellent handling through corners.



## XUV855M

Diesel Engine	
Displacement: 854 cc	
Speed: 40 km/h	
4-Wheel Drive	
Fully Independent Suspension	
Power Steering: Standard	
Towing Capacity: 680 kg	
Cargo Capacity: 454 kg	
– Road Homologation*	

\* Homologation type may vary by country.  
Please refer to your dealer.

## ROAD READY

All our XUVs are fully homologated and ready for use on public roads.



# GATOR XUV855M S4

ROOM FOR FOUR PLUS PLENTY MORE

Need room for more? When you're expecting company or your job demands added manpower, the XUV855M S4 is the way to go. It seats four people comfortably with enough space for all your tools and equipment. Even when fully loaded, its power and acceleration will be sure to impress.



## A RIDE TO REMEMBER

The XUV855M S4 is powered by an 854 cc (0.854 L), three-cylinder, liquid-cooled, four-cycle diesel engine that delivers superb starting, idling and throttle response during operation. Minimal noise vibration and harshness (NVH) along with hydraulic disc brakes and power steering allow you to operate this surprisingly nimble four-seater smoothly.



## CONVERTIBLE REAR BENCH

The rear bench folds down in seconds when you need to carry long items or store your things.





### PLENTY OF SPACE FOR FOUR

Four seats. True, on demand 4-wheel drive and fully independent suspension for a smooth, comfortable ride.



### XUV855M S4

Diesel Engine
Displacement: 854 cc
Speed: 51 km/h
4-Wheel Drive
Fully Independent Suspension
Power Steering: Standard
Towing Capacity: 680 kg
Cargo Capacity: 454 kg

– Road Homologation\*

\* Homologation type may vary by country. Please refer to your dealer.



### FULL-SIZE CARGO BOX

Even though the S4 version seats four, it has the same size cargo box as the XUV855M two-seater. The box consists of a noise-reducing, 15% glass-filled polypropylene composite material that eliminates rust and dents and can easily be converted into a flat bed. This configuration is ideal for loading larger cargo.

# FEATURES

## XUV835M, XUV865M & XUV865R – CROSS-OVER VEHICLES

Once you experience the XUV835M, XUV865M and XUV865R cross-over utility vehicles, you won't look any further. These top-of-the-line Gators tick all the boxes in terms of power, capacity and car-style comfort. Not to mention their slick design.



### RIDE IN STYLE

Whether it is a completely open operator station or a factory-installed cab, the interior has been designed with comfort and ergonomics in mind.



### OPEN OR CLOSED?

Choose either an open cab with nets, or the fully-enclosed cab with poly doors for maximum protection and minimum noise.





### SPACIOUS CAB

The cab on these models raises the bar in terms of comfort, space and storage.



### POWERFUL HVAC SYSTEM

With four adjustable dash vents and three fan speeds, the efficient heating, ventilation, and air conditioning (HVAC) system keeps you at the perfect temperature year-round. Automotive-style controls in the centre of the dash make for easy and convenient use by the operator or passengers (Standard on the XUV865R, optional for XUV835M and XUV865M).





## STAND OUT OR BLEND IN

The GATOR XUV835M and XUV865M models come in three different colorways. Have your say and choose between the John Deere Green & Yellow, Olive & Black or woodland Camouflage. It's your call.



## TAKE IT AWAY

Heavy or bulky loads? No problem – these models have ample towing and cargo capacity, plus roadholding and brakes to match.

With an optional Power Lift, your Gator doubles as a dump truck.



## WIRED FOR ACTION

The cab comes with all cables pre-installed, so hooking up a winch is really easy.



## GO HIGHER

With true on-demand 4-wheel drive and even more ground clearance, both models go where others can't when conditions are tricky.



**“THERE’S NO  
SUCH THING AS A  
TYPICAL DAY FOR  
A RANGER.”**

KARL MITTERHAUSER

**WORK  
DONE WELL.**

»*WORK. DONE WELL.*«



Rain or shine, Karl Mitterhauser tours his region daily to see things are running smoothly. “There’s a lot of hunting work and tourism, and timber is harvested every day.” The weather is as varied as the terrain, but Karl’s Gator always gets him where he needs to go. ■

# GATOR XUV835M

# GATOR XUV865M

THE ULTIMATE IN COMFORT AND PERFORMANCE

Whatever the challenge, the Gator XUV835M and the Gator XUV865M are ready to take it on. Be it comfort or performance, these two vehicles are all about setting new standards.



## CHOOSE YOUR FUEL

Both models offer car-style comfort and controls. Choose between a petrol powered XUV835M or the Diesel-powered XUV865M.



**More Manpower:** In need of an extra pair of hands? Simply adjust the driver seat and make room for more. The Gator XUV835M & Gator XUV 865M cab can comfortably seat up to three passengers, when not on public roads.



**Additional Storage:** You can never have enough storage room. To make sure your equipment and personal items are safely stored away and out of sight, just tip the passenger bench forward and use the extra storage space underneath.







**Easy Access:** When navigating narrow spaces, you will find these Gators are astonishingly compact and offer all-round visibility.



### XUV835M

Petrol Engine
Displacement: 812 cc
Speed: 60 km/h
4-Wheel Drive
Fully Independent Suspension
Power Steering: Standard
Towing Capacity: 900 kg
Cargo Capacity: 454 kg

- optional heating and air conditioning
- Road Homologation\*

\* Homologation type may vary by country. Please refer to your dealer.



### XUV865M

Diesel Engine
Displacement: 854 cc
Speed: 50 km/h
4-Wheel Drive
Fully Independent Suspension
Power Steering: Standard
Towing Capacity: 900 kg
Cargo Capacity: 454 kg

- optional heating and air conditioning
- Road Homologation\*

\* Homologation type may vary by country. Please refer to your dealer.

# XUV865R

AS COMFORTABLE AS WORK GETS

The XUV865R is the most comfortable Gator in the John Deere family. It combines the remarkable performance of the XUV835M and XUV865M cross-over utility vehicles with a wide range of additional features for even more comfort – you might just keep on working.



## WORK IN COMFORT

Standard features include car-style seating, easy-open door handles and a windscreen that opens fully; options include heating, ventilation and air conditioning (HVAC). The styled roof moves water to the outside edges, and front/rear lights are below the roof line for better protection.

## A FRESH LOOK

The R trim provides your cab with a wide array of extras, ranging from a tan interior to electrical wiring for attachments as well as heating, ventilation and air conditioning (HVAC). It also includes a tan cloth 40/60 bench seat, A and B post covers, a rear panel cover, tan door panels, an interior rearview mirror, high- and low-beam LED headlights, a dome light, sun visors, a windshield wiper and washer.





## IDEAL WORKING CLIMATE

With four dash vents, four air flow modes and three fan speeds, the efficient heating, ventilation and air conditioning (HVAC) system helps you control your working temperature year-round. Easy-to-use automotive-style controls are conveniently located in the centre of the dash, within reach of the operator and passengers.



## XUV865R

Diesel Engine
Displacement: 854 cc
Speed: 50 km/h
4-Wheel Drive
Fully Independent Suspension
Power Steering: Standard
Towing Capacity: 900 kg
Cargo Capacity: 454 kg

- HVAC (heating and air conditioning)
- Road Homologation\*

\* Homologation type may vary by country. Please refer to your dealer.

# GATOR ATTACHMENTS



# T-SERIES



## CARGO BOX

### 1 Cargo Box Divider

The deluxe cargo box can be equipped with optional dividers, that can be positioned at the front or rear and released quickly without any tools.

### 2 Cargo Box Power Lift

Easily lower and raise the cargo box from the seat with the dash-mounted switch. Electro-mechanically activated, rated for full box capacity.

### 3 Cargo Box Side Extension

Cargo Box Side Extensions let you haul twice the amount of light materials like clippings and mulch. Tailgate pivots at the top (similar to a dump truck) for ease of unloading loose material (TX, TX-Turf, TE, TH).

### 4 Cargo Box Tool Rack

The side tool rack enables you to maximise the use of the cargo box by carrying long-handled tools. The holders are adjustable, allowing you to carry a wide array of items in the racks.

### 5 Cargo Box Fender Guard

Easily-installed heavy-duty guard protects cargo box and won't interfere with dumping operation – with either gas-assisted dumping or power lift option (TX 4x2, TE 4x2).

## ROAD HOMOLOGATION

### Public Roads

The use of Gators on public roads is subject to approval by national authorities. Please ask your dealer for details of our lighting kits, mirrors and other essentials.



## LIGHTING

### 6 Brake and Tail Light Kit

Make your Gator more visible in all conditions by adding the brake and tail light kit.

## BUMPER

### 7 Front Bumper

Strong, front-mounted, modern bumper with brush guard creates a sleek, aggressive appearance for all Gator T-Series models.

### 8 Heavy Duty Brush Guard

Composed of strong tubular steel, the heavy-duty bumper and brushguard protect the unit from front impacts – and adds increased protection to the grille and headlights.

### 9 Front Fender Guard

Durable tubing provides additional protection for the front grille, lights and fenders.

### 10 Rear Bumper

The rear bumper offers stylish, heavy duty rear protection to the vehicle.

## DRAWBAR

### 11 Drawbar Hitch

Can be mounted in the standard rear receiver hitch or the optional front receiver hitch for towing trailers.

## OPERATOR'S STATION

### 12 Windscreen

Easy to attach, height-adjustable tinted acrylic windscreen to protect the operator from dust and wind.

### 13 Floor Mat

Washable mat protects the floor and minimises dust, debris and noise in the operator station.

### 14 Seats

Ride in style and comfort with our high back or bucket seats. The choice is yours!

## Safety

Your safety is our top priority. That's why every Gator model has comfortable car-style 3-point seat belts as standard.



## FRONT RACK

### 15 Front Hood Rack

This generously sized rack will haul up to a 45 kg payload. Tilts forward, in conjunction with the brush guard, for full access to under-hood storage and service points.

## ROPS

### 16 T-Series ROPS

Add a spacious ROPS (Roll Over Protection Structure) – certified to your GATOR T-Series UV for year-round protection. Optional front windshield, glass doors and glass rear window available.

## BLADES

### 17 72 Front Blade (1.83 m)

- Snow removal / light material blading
- 3-position manual angling
- Electro-hydraulic lift system
- Quick attach system
- Two adjustable skid shoes
- Replaceable cutting edge

### 72 V-Front Blade (1.83 m)

- Snow removal / light material blading
- 3-position manual angling
- Electro-hydraulic lift system
- Quick attach system
- Two adjustable skid shoes
- Replaceable cutting edge

## TYRES

### 18 Turf

- Gentle to the turf
- Very good traction on damp surfaces
- High level of comfort
- Low wear on hard surfaces

### 19 Cayman AT (All Terrain)

- Universal all-round tyres for on and off-road use
- Good traction off-road
- Low ground pressure

### 20 Cayman XT (Extreme Terrain)

- Outstanding traction off-road
- Puncture resistant
- Can also be used on-road

# XUV560E & XUV590M



## CARGO BOX

### 1 Cargo Box Power Lift

Easily lower and raise the cargo box from the seat with the dash-mounted switch. Electro-mechanically activated, rated for full box capacity.

### 2 Cargo Box Side Extensions

Extend your cargo space with these Quick-Clamp extensions.

### Cargo Box Fender Guard

The cargo box fender guard offers enhanced styling in addition to heavy duty protection to the side of the cargo box.

## LIGHTING

### 3 LED Work Lights

Additional LED work light kits available.

## SPEED CONTROL

### 4 Digital Dashboard

All the information you need easy to read in all light conditions (XUV560E and XUV590M).





## FRAME / BUMPER

### 5 Heavy Duty Brush Guard

Strong bumper-mounted heavy duty brush guard provide aggressive appearance.

### 6 Fender Guards

Heavy duty fender guards not only prevent damage from side impact but also create a modern and aggressive appearance.

### 7 Deflector Plate

The polyethylene skid plate slides over obstacles easily while protecting your frame and power train from dirt, debris and damage.

### 8 Rear Bumper

Protects cargo box and tailgate.

## OPERATOR'S STATION

### 9 Hard Plastic Door

These doors are ideal for all season weather protection. Not for road homologation.

### 10 Roof & Rear Screen

Add more protection from the elements, rear screen includes headrest.

### 11 Rear Screen

Add more protection from the elements with a hard plastic screen.



### 12 Sport Steering Wheel

Color accents and a comfortable feel make this a must-have.

### 13 Nets

The nets offer increased safety and protection (standard on XUV560E and XUV590M S4).

### 14 Half Poly Doors

These half doors are standard on XUV590M (2-Seater).



### Seats

Ride in style and comfort with our high back or bucket seats. The choice is yours!

### Safety

Your safety is our top priority. That's why every Gator has comfortable car-style 3-point seat belts as standard.

### 15 High-Back Bucket Seats

### 16 Windscreens

Half, full (shown), and full glass.



## STORAGE AND RACKS

### 17 Front Hood Rack

Generously sized rack (122 cm long, 34 cm wide by 9 cm deep) will carry up to 45 kg of gear.

### 18 Winch

- For loads up to 1587 kg
- Designed for moving logs, pulling out bushes with control or tension fences
- Increased efficiency and improved load distribution due to quiet, three-stage planetary gear design
- Mounts front and rear



## BLADES

### 19 66 Front Blade (1.68 m)

- Snow removal/light material blading
- 5-position manual angling
- Winch operated (requires additional attachments)
- Two adjustable skid shoes
- Replaceable cutting edge

## TYRES

### 20 Terra-Hawk AT (All Terrain)

- Universal all-round tyres for on and off-road use
- Good traction off-road
- Low ground pressure

### 21 Maxxis Big Horn 2.0 Radials

- Radial tyre construction provides better shock absorption
- Alloy rims for maximum performance and look
- Non-directional tread pattern provides predictable cornering and claws up roots and rocks
- 6-ply rating for maximum puncture resistance and lifetime

# XUV835M, XUV855M, XUV865M , XUV865R & HPX815E



## AG MANAGEMENT SOLUTION

### AMS Integration kit

Mount a StarFire receiver and GS display (both sold separately) for even higher productivity.

## BLADES

### 1 72 Front Blade (1.83 m)

### 2 72 V-Front Blade (1.83 m)

- Snow removal / light material blading
- 3-position manual angling
- Electro-hydraulic lift system
- Quick attach system
- Two adjustable skid shoes
- Replaceable cutting edge (XUV855M, HPX815E)

### 3 72 Hydraulic Operated Straight Blade (1.83 m)

- Snow removal / light material blading
- Hydraulic angling
- Full-trip moldboard for plow protection (XUV835M, XUV865M, XUV865R)

## CARGO BOX

### 4 Cargo Box Side Extension

Haul twice the amount of clippings or mulch with these durable extensions. The tailgate pivots at the top for easier dumping. (XUV835M, XUV855M, XUV855M S4, XUV865R) Mesh style side extensions available for HPX815E.

### 5 Cargo Box Divider

Make the most of your deluxe cargo box with these quick-release dividers. No tools required.



#### **6** Cargo Box Tool Rack

Save valuable cargo space by attaching long tools to this adjustable rack.

#### **7** Cargo Box Powerlift

Easily lower and raise the cargo box from the seat with the dash-mounted switch. Electro-mechanically activated, rated for full box capacity (Standard on the XUV835M, XUV865M, XUV865R).

### **HORN**

#### **8** Horn Kit

Includes horn, mounting brackets, wire harness and switch.



### **LIGHTING**

#### **9** LED Driving Lights

State-of-the-art driving lights for safer operation all year round.

#### **10** LED Work Lights

Bolt these lights to the front of your cab frame for clear, consistent lighting (Standard on the XUV865R).

#### **11** Beacon Light

High-visibility rotary light with rugged amber lenses and an overhead-mounted on/off rocker switch.



### **GUARDS**

#### **Cargo Box Fender Guard**

The cargo box fender guard offers enhanced styling in addition to heavy duty protection to the side of the cargo box.

#### **12 + 13** Heavy-Duty Brush Guard

Strong bumper-mounted heavy duty brush guard provides a modern and aggressive appearance. Pictures display the extended version with additional side extensions (not included as standard).



## HITCHES

### 14 Rear Bumper

The rear bumper offers stylish, heavy duty rear protection to the vehicle.

### 15 Rear Fender Guard

Heavy duty fender guards not only prevent damage from side impact but also create a modern and aggressive appearance.

### 16 Rear Panel Glass Protector

This durable screen protects your cab's rear window without impairing visibility.

### 17 Draw Bar / Ball Hitches

Can be mounted in the standard rear receiver hitch or the optional front receiver hitch for towing trailers.

## OPERATOR'S STATION

### 18 Poly Doors for Deluxe Cab

Comes equipped with manual roll down window and numerous storage compartments.

### 19 Floor Mat

Washable mat protects the floor and minimises dust, debris and noise in the operator station.



20



21



22



23



24



25



26



27

### 20 Deluxe Cab Frame

Certified to the Society of Automotive Engineers (SAE) requirements to provide roll-over protection. Includes 3-point seat belts and can be enhanced to a full comfort cab.

### 21 Cab Heater

Stay warm all year round. High-output two-speed heater also defrosts windshield. Requires appropriate Heater Fitting Kit.

### 22 Sport Steering Wheel

Color accents and a comfortable feel make this a must-have (standard on XUV865R).

### 23 Rear Mirror

Add car-standard visibility to your Gator with this rugged foldable rear mirror (Standard on the XUV865R).

### Tablet Mount & Cell Phone Holder

This rugged dash-mounted holder keeps devices safe when the going gets rough.

### Radio Kit

Contains everything you need for fast, easy installation. Radio not included.

### Seats

Ride in style and comfort with our high back or bucket seats. The choice is yours!

### Safety

Your safety is our top priority. That's why every Gator Utility Vehicle has comfortable car-style 3-point seat belts as standard.

**24 Sport Seat** (Available for XUV835M, XUV855M and XUV865M)

**25 High-Back Bucket Seats** (not available at XUV865R)

**26 Bench Seat "Yellow"** (XUV835M, XUV865M)

**27 Bench Seat "Tant"** (XUV865R)



## WINDSHIELD

### 28 Washer and Wiper Kit

For car-style safety in wet or muddy conditions.

## FRONT RACK

### 29 Front Hood Rack

Expand the work capabilities of your Gator Utility Vehicle with the addition of the front bonnet rack. The rack easily mounts to the required front brush guard. Next to the rack the picture shows the brush guard, brush guard extensions and front fender guards.

## WINCH

### 30 + 31 Winch

- For loads up to HPX815E: 1587 kg (3500 lbs), XUV835M, XUV865M and XUV865R: up to 2041 kg (4500 lbs) and XUV855M: up to 1587 kg (3500 lbs)
- Designed for moving logs, pulling out bushes with control or tension fences
- Increased efficiency and improved load distribution due to quiet, three-stage planetary gear design
- Mounts front and rear

### Wireless Winch Remote

For instant, push-button winch control from inside or outside the vehicle. (for the XUV835M, XUV865M, XUV865R)





## TYRES

### 32 Turf

- Gentle to the turf
- Very good traction on damp surfaces
- High level of comfort
- Low wear on hard surfaces (Fits HPX815E)

### 33 Terra-Hawk AT (All Terrain)

- Universal all-round tyres for on and off-road use
- Good traction off-road
- Low ground pressure (Fits XUV835M, XUV855M, XUV865M, XUV865R, not compatible with XUV855M S4)

### 34 Steel rims for Maxxis tyres

- Larger 14" diameter improves ride and performance
- Bigger holes for easier cleaning (Fits XUV835M, XUV855M, XUV855M S4, XUV865M, XUV865R)

### 35 Maxxis Big Horn 2.0 Radials

- Radial tyre construction provides better shock absorption
- Alloy rims for maximum performance and look
- Non-directional tread pattern provides predictable cornering and claws up roots and rocks
- 6-ply rating for maximum puncture resistance and lifetime (Fits XUV835M, XUV855M, XUV855M S4, XUV865M, XUV865R)

### 36 HPAP (High Performance All Purpose)

- Optimal traction
- Minimal impact on terrain (Fits HPX815E)

### 37 HPAT (High Performance All Terrain)

- Aggressive off-road tread pattern for extra traction (Fits HPX815E)

# ATTACHMENTS

FIND WHAT YOU'RE LOOKING FOR HERE

	TS	TX	TX Turf	TE	TH	HPX 815E	XUV 560E	XUV 590M	XUV 590M S4	XUV 855M	XUV 855M S4	XUV 835M	XUV 865M	XUV 865R
<b>CABS / CANOPIES / OPS</b>														
Deluxe Canopy (Includes Roof)	<input type="checkbox"/>	<input type="checkbox"/>	<input type="checkbox"/>	<input type="checkbox"/>	<input type="checkbox"/>	<input checked="" type="checkbox"/>				<input checked="" type="checkbox"/>		<input checked="" type="checkbox"/>	<input checked="" type="checkbox"/>	<input checked="" type="checkbox"/>
Standard OPS (Operator Protective Structure)							<input checked="" type="checkbox"/>	<input checked="" type="checkbox"/>	<input checked="" type="checkbox"/>		<input checked="" type="checkbox"/>			
Nets						<input checked="" type="checkbox"/>	<input checked="" type="checkbox"/>		<input checked="" type="checkbox"/>	<input checked="" type="checkbox"/>	<input checked="" type="checkbox"/>	<input checked="" type="checkbox"/>	<input checked="" type="checkbox"/>	<input type="checkbox"/>
Standard OPS Poly Roof							<input type="checkbox"/>	<input type="checkbox"/>	<input type="checkbox"/>		<input type="checkbox"/>			
Standard OPS Soft Roof							<input type="checkbox"/>	<input type="checkbox"/>						
Front Windshield / Windscreen	<input type="checkbox"/>	<input type="checkbox"/>	<input type="checkbox"/>	<input type="checkbox"/>	<input type="checkbox"/>	<input type="checkbox"/>	<input type="checkbox"/>	<input type="checkbox"/>	<input type="checkbox"/>	<input type="checkbox"/>	<input type="checkbox"/>	<input checked="" type="checkbox"/>	<input checked="" type="checkbox"/>	<input checked="" type="checkbox"/>
Standard OPS Half Windshield							<input type="checkbox"/>	<input type="checkbox"/>	<input type="checkbox"/>					
Rear Window / Screen Panel	<input type="checkbox"/>	<input type="checkbox"/>	<input type="checkbox"/>	<input type="checkbox"/>	<input type="checkbox"/>	<input type="checkbox"/>	<input type="checkbox"/>	<input type="checkbox"/>	<input type="checkbox"/>	<input type="checkbox"/>	<input type="checkbox"/>	<input checked="" type="checkbox"/>	<input checked="" type="checkbox"/>	<input checked="" type="checkbox"/>
Exterior Mirrors	<input type="checkbox"/>	<input type="checkbox"/>	<input type="checkbox"/>	<input type="checkbox"/>	<input type="checkbox"/>	<input checked="" type="checkbox"/>	<input checked="" type="checkbox"/>	<input checked="" type="checkbox"/>	<input checked="" type="checkbox"/>	<input checked="" type="checkbox"/>	<input checked="" type="checkbox"/>	<input checked="" type="checkbox"/>	<input checked="" type="checkbox"/>	<input checked="" type="checkbox"/>
Windshield with Wiper Kit	<input type="checkbox"/>	<input type="checkbox"/>	<input type="checkbox"/>	<input type="checkbox"/>	<input type="checkbox"/>	<input type="checkbox"/>	<input type="checkbox"/>	<input type="checkbox"/>	<input type="checkbox"/>			<input checked="" type="checkbox"/>	<input checked="" type="checkbox"/>	<input checked="" type="checkbox"/>
Windshield Washer Kit	<input type="checkbox"/>	<input type="checkbox"/>	<input type="checkbox"/>	<input type="checkbox"/>	<input type="checkbox"/>	<input type="checkbox"/>	<input type="checkbox"/>	<input type="checkbox"/>	<input type="checkbox"/>			<input checked="" type="checkbox"/>	<input checked="" type="checkbox"/>	<input checked="" type="checkbox"/>
Heater Kit					<input type="checkbox"/>	<input type="checkbox"/>		<input type="checkbox"/>	<input type="checkbox"/>	<input type="checkbox"/>	<input type="checkbox"/>	<input type="checkbox"/>	<input type="checkbox"/>	
Visor	<input type="checkbox"/>	<input type="checkbox"/>	<input type="checkbox"/>	<input type="checkbox"/>	<input type="checkbox"/>	<input type="checkbox"/>				<input type="checkbox"/>		<input type="checkbox"/>	<input type="checkbox"/>	<input checked="" type="checkbox"/>
Interior Light	<input type="checkbox"/>	<input type="checkbox"/>	<input type="checkbox"/>	<input type="checkbox"/>	<input type="checkbox"/>	<input type="checkbox"/>				<input type="checkbox"/>				<input checked="" type="checkbox"/>
Rear Screen						<input type="checkbox"/>	<input type="checkbox"/>	<input type="checkbox"/>	<input checked="" type="checkbox"/>	<input type="checkbox"/>	<input checked="" type="checkbox"/>	<input type="checkbox"/>	<input type="checkbox"/>	<input checked="" type="checkbox"/>
<b>DOORS</b>														
Half Doors								<input checked="" type="checkbox"/>			<input type="checkbox"/>			
Full Glass	<input type="checkbox"/>	<input type="checkbox"/>	<input type="checkbox"/>	<input type="checkbox"/>	<input type="checkbox"/>	<input type="checkbox"/>				<input type="checkbox"/>				
Poly Cab Doors							<input type="checkbox"/>	<input type="checkbox"/>			<input type="checkbox"/>			
Deluxe Poly Doors						<input type="checkbox"/>				<input type="checkbox"/>		<input type="checkbox"/>	<input type="checkbox"/>	<input checked="" type="checkbox"/>
Canvas Doors								<input type="checkbox"/>						
<b>SEATS</b>														
High-Back Bucket Seats	<input checked="" type="checkbox"/>	<input checked="" type="checkbox"/>	<input checked="" type="checkbox"/>	<input checked="" type="checkbox"/>	<input checked="" type="checkbox"/>	<input checked="" type="checkbox"/>	<input checked="" type="checkbox"/>	<input checked="" type="checkbox"/>	<input checked="" type="checkbox"/>	<input checked="" type="checkbox"/>	<input checked="" type="checkbox"/>	<input checked="" type="checkbox"/>	<input checked="" type="checkbox"/>	<input checked="" type="checkbox"/>
Bench Seat										<input type="checkbox"/>		<input type="checkbox"/>	<input type="checkbox"/>	<input checked="" type="checkbox"/>
Sport Seat										<input type="checkbox"/>		<input type="checkbox"/>	<input type="checkbox"/>	
Adjustable Driver Seat	<input type="checkbox"/>	<input type="checkbox"/>	<input type="checkbox"/>	<input type="checkbox"/>	<input type="checkbox"/>	<input checked="" type="checkbox"/>	<input checked="" type="checkbox"/>	<input checked="" type="checkbox"/>	<input checked="" type="checkbox"/>	<input checked="" type="checkbox"/>	<input checked="" type="checkbox"/>	<input checked="" type="checkbox"/>	<input checked="" type="checkbox"/>	<input checked="" type="checkbox"/>
<b>HOMOLOGATION</b>														
Road Homologation*	<input type="checkbox"/>	<input type="checkbox"/>	<input type="checkbox"/>	<input type="checkbox"/>	<input type="checkbox"/>	<input checked="" type="checkbox"/>	<input checked="" type="checkbox"/>	<input checked="" type="checkbox"/>	<input checked="" type="checkbox"/>	<input checked="" type="checkbox"/>	<input checked="" type="checkbox"/>	<input checked="" type="checkbox"/>	<input checked="" type="checkbox"/>	<input checked="" type="checkbox"/>
<b>PROTECTION</b>														
Front Bumper	<input type="checkbox"/>	<input type="checkbox"/>	<input type="checkbox"/>	<input type="checkbox"/>		<input checked="" type="checkbox"/>	<input checked="" type="checkbox"/>	<input checked="" type="checkbox"/>	<input checked="" type="checkbox"/>	<input checked="" type="checkbox"/>	<input checked="" type="checkbox"/>	<input type="checkbox"/>	<input type="checkbox"/>	<input type="checkbox"/>
Brush Guard	<input type="checkbox"/>	<input type="checkbox"/>	<input type="checkbox"/>	<input type="checkbox"/>		<input type="checkbox"/>	<input type="checkbox"/>	<input type="checkbox"/>	<input type="checkbox"/>	<input type="checkbox"/>	<input type="checkbox"/>	<input type="checkbox"/>	<input type="checkbox"/>	<input type="checkbox"/>
Fender Guard	<input type="checkbox"/>	<input type="checkbox"/>	<input type="checkbox"/>	<input type="checkbox"/>		<input type="checkbox"/>	<input type="checkbox"/>	<input type="checkbox"/>	<input type="checkbox"/>	<input type="checkbox"/>	<input type="checkbox"/>	<input type="checkbox"/>	<input type="checkbox"/>	<input type="checkbox"/>
CV Guards (Front and Rear)						<input type="checkbox"/>	<input type="checkbox"/>	<input type="checkbox"/>	<input type="checkbox"/>	<input type="checkbox"/>	<input type="checkbox"/>	<input type="checkbox"/>	<input type="checkbox"/>	<input type="checkbox"/>
Deflector Plate							<input type="checkbox"/>	<input type="checkbox"/>						
Rear Bumper		<input type="checkbox"/>	<input type="checkbox"/>	<input type="checkbox"/>	<input type="checkbox"/>		<input checked="" type="checkbox"/>	<input checked="" type="checkbox"/>	<input checked="" type="checkbox"/>	<input checked="" type="checkbox"/>	<input checked="" type="checkbox"/>	<input type="checkbox"/>	<input type="checkbox"/>	<input type="checkbox"/>
Brake and Taillight Protector		<input type="checkbox"/>	<input type="checkbox"/>	<input type="checkbox"/>	<input type="checkbox"/>					<input type="checkbox"/>	<input type="checkbox"/>	<input type="checkbox"/>	<input type="checkbox"/>	<input type="checkbox"/>
Floor Mat	<input type="checkbox"/>	<input type="checkbox"/>	<input type="checkbox"/>	<input type="checkbox"/>	<input type="checkbox"/>	<input type="checkbox"/>	<input type="checkbox"/>	<input type="checkbox"/>	<input type="checkbox"/>	<input type="checkbox"/>	<input type="checkbox"/>	<input type="checkbox"/>	<input type="checkbox"/>	<input type="checkbox"/>
Front Hood Rack	<input type="checkbox"/>	<input type="checkbox"/>	<input type="checkbox"/>	<input type="checkbox"/>	<input type="checkbox"/>	<input type="checkbox"/>	<input type="checkbox"/>	<input type="checkbox"/>	<input type="checkbox"/>	<input type="checkbox"/>	<input type="checkbox"/>	<input type="checkbox"/>	<input type="checkbox"/>	<input type="checkbox"/>
HD Front Suspension	<input type="checkbox"/>	<input type="checkbox"/>	<input type="checkbox"/>	<input type="checkbox"/>	<input type="checkbox"/>	<input type="checkbox"/>				<input checked="" type="checkbox"/>	<input checked="" type="checkbox"/>	<input checked="" type="checkbox"/>	<input checked="" type="checkbox"/>	<input checked="" type="checkbox"/>

	TS	TX	TX Turf	TE	TH	HPX 815E	XUV 560E	XUV 590M	XUV 590M S4	XUV 855M	XUV 855M S4	XUV 835M	XUV 865M	XUV 865R
<b>LIGHTS</b>														
Beacon Light	<input type="checkbox"/>	<input type="checkbox"/>	<input type="checkbox"/>	<input type="checkbox"/>	<input type="checkbox"/>	<input type="checkbox"/>	<input type="checkbox"/>	<input type="checkbox"/>	<input type="checkbox"/>	<input type="checkbox"/>	<input type="checkbox"/>	<input type="checkbox"/>	<input type="checkbox"/>	<input type="checkbox"/>
Work Lights Front (2)	<input type="checkbox"/>	<input type="checkbox"/>	<input type="checkbox"/>	<input type="checkbox"/>	<input type="checkbox"/>	<input type="checkbox"/>				<input type="checkbox"/>		<input type="checkbox"/>	<input type="checkbox"/>	<input type="checkbox"/>
Work Light Rear (1)	<input type="checkbox"/>	<input type="checkbox"/>	<input type="checkbox"/>	<input type="checkbox"/>	<input type="checkbox"/>	<input type="checkbox"/>				<input type="checkbox"/>		<input type="checkbox"/>	<input type="checkbox"/>	<input type="checkbox"/>
LED Worklights fit Roof/OPS, Front/Rear							<input type="checkbox"/>	<input type="checkbox"/>	<input type="checkbox"/>	<input type="checkbox"/>	<input type="checkbox"/>	<input type="checkbox"/>	<input type="checkbox"/>	<input checked="" type="checkbox"/>
Deluxe Light Kit	<input type="checkbox"/>	<input type="checkbox"/>	<input type="checkbox"/>	<input type="checkbox"/>	<input type="checkbox"/>	<input type="checkbox"/>	<input type="checkbox"/>	<input type="checkbox"/>	<input type="checkbox"/>	<input type="checkbox"/>	<input type="checkbox"/>	<input type="checkbox"/>	<input type="checkbox"/>	<input type="checkbox"/>
Brake / Tail Light Kit	<input type="checkbox"/>	<input type="checkbox"/>	<input type="checkbox"/>	<input type="checkbox"/>	<input type="checkbox"/>	<input type="checkbox"/>	<input checked="" type="checkbox"/>	<input checked="" type="checkbox"/>	<input checked="" type="checkbox"/>	<input checked="" type="checkbox"/>	<input checked="" type="checkbox"/>	<input checked="" type="checkbox"/>	<input checked="" type="checkbox"/>	<input checked="" type="checkbox"/>
OPS Switch Bank							<input type="checkbox"/>	<input type="checkbox"/>	<input type="checkbox"/>		<input type="checkbox"/>			
<b>CARGO BOX</b>														
Cargo Box Lift Manual	<input checked="" type="checkbox"/>	<input checked="" type="checkbox"/>	<input checked="" type="checkbox"/>	<input checked="" type="checkbox"/>	<input checked="" type="checkbox"/>	<input checked="" type="checkbox"/>	<input checked="" type="checkbox"/>	<input checked="" type="checkbox"/>	<input checked="" type="checkbox"/>	<input checked="" type="checkbox"/>	<input checked="" type="checkbox"/>	<input checked="" type="checkbox"/>	<input checked="" type="checkbox"/>	<input checked="" type="checkbox"/>
Cargo Box Power Lift	<input type="checkbox"/>	<input type="checkbox"/>	<input type="checkbox"/>	<input type="checkbox"/>	<input type="checkbox"/>	<input type="checkbox"/>	<input type="checkbox"/>	<input type="checkbox"/>	<input type="checkbox"/>	<input type="checkbox"/>	<input type="checkbox"/>	<input type="checkbox"/>	<input type="checkbox"/>	<input checked="" type="checkbox"/>
Cargo Box Side Wall Extension		<input type="checkbox"/>	<input type="checkbox"/>	<input type="checkbox"/>	<input type="checkbox"/>		<input type="checkbox"/>	<input type="checkbox"/>	<input type="checkbox"/>	<input type="checkbox"/>	<input type="checkbox"/>	<input type="checkbox"/>	<input type="checkbox"/>	<input type="checkbox"/>
Cargo Box Divider Kit		<input type="checkbox"/>	<input type="checkbox"/>	<input type="checkbox"/>	<input type="checkbox"/>					<input type="checkbox"/>	<input type="checkbox"/>	<input type="checkbox"/>	<input type="checkbox"/>	<input type="checkbox"/>
Cargo Box Tool Rack		<input type="checkbox"/>	<input type="checkbox"/>	<input type="checkbox"/>	<input type="checkbox"/>					<input type="checkbox"/>	<input type="checkbox"/>	<input type="checkbox"/>	<input type="checkbox"/>	<input type="checkbox"/>
Cargo Box Fender Guard		<input type="checkbox"/>	<input type="checkbox"/>	<input type="checkbox"/>			<input type="checkbox"/>	<input type="checkbox"/>	<input type="checkbox"/>	<input type="checkbox"/>	<input type="checkbox"/>	<input type="checkbox"/>	<input type="checkbox"/>	<input type="checkbox"/>
Cargo Box Bedliner	<input type="checkbox"/>					<input type="checkbox"/>								
Cargo Box Rails							<input type="checkbox"/>	<input type="checkbox"/>	<input type="checkbox"/>					
Cargo Box Spray in Bedliner		<input checked="" type="checkbox"/>	<input checked="" type="checkbox"/>	<input checked="" type="checkbox"/>	<input checked="" type="checkbox"/>		<input checked="" type="checkbox"/>	<input checked="" type="checkbox"/>	<input checked="" type="checkbox"/>	<input checked="" type="checkbox"/>	<input checked="" type="checkbox"/>	<input checked="" type="checkbox"/>	<input checked="" type="checkbox"/>	<input checked="" type="checkbox"/>
Cargo Box Mat		<input type="checkbox"/>	<input type="checkbox"/>	<input type="checkbox"/>	<input type="checkbox"/>		<input type="checkbox"/>	<input type="checkbox"/>		<input type="checkbox"/>	<input type="checkbox"/>	<input type="checkbox"/>	<input type="checkbox"/>	<input type="checkbox"/>
Cargo Box Rubber Mat	<input type="checkbox"/>					<input type="checkbox"/>								
Cargo Box Side Storage Box	<input type="checkbox"/>	<input type="checkbox"/>	<input type="checkbox"/>			<input type="checkbox"/>								
<b>HITCH</b>														
Rear Hitch	<input type="checkbox"/>	<input type="checkbox"/>	<input type="checkbox"/>	<input type="checkbox"/>	<input type="checkbox"/>	<input type="checkbox"/>	<input type="checkbox"/>	<input type="checkbox"/>	<input type="checkbox"/>	<input type="checkbox"/>	<input type="checkbox"/>	<input type="checkbox"/>	<input type="checkbox"/>	<input type="checkbox"/>
Ball Hitch	<input type="checkbox"/>	<input type="checkbox"/>	<input type="checkbox"/>	<input type="checkbox"/>	<input type="checkbox"/>	<input type="checkbox"/>	<input type="checkbox"/>	<input type="checkbox"/>	<input type="checkbox"/>	<input type="checkbox"/>	<input type="checkbox"/>	<input type="checkbox"/>	<input type="checkbox"/>	<input type="checkbox"/>
Rear Receiver	<input type="checkbox"/>	<input type="checkbox"/>	<input type="checkbox"/>	<input type="checkbox"/>	<input type="checkbox"/>	<input type="checkbox"/>	<input checked="" type="checkbox"/>	<input checked="" type="checkbox"/>	<input checked="" type="checkbox"/>	<input checked="" type="checkbox"/>	<input checked="" type="checkbox"/>	<input checked="" type="checkbox"/>	<input checked="" type="checkbox"/>	<input checked="" type="checkbox"/>
Drawbar	<input type="checkbox"/>	<input type="checkbox"/>	<input type="checkbox"/>	<input type="checkbox"/>	<input type="checkbox"/>	<input type="checkbox"/>	<input type="checkbox"/>	<input type="checkbox"/>	<input type="checkbox"/>	<input type="checkbox"/>	<input type="checkbox"/>	<input type="checkbox"/>	<input type="checkbox"/>	<input type="checkbox"/>
Front Receiver	<input type="checkbox"/>	<input type="checkbox"/>		<input type="checkbox"/>		<input checked="" type="checkbox"/>	<input checked="" type="checkbox"/>	<input checked="" type="checkbox"/>	<input checked="" type="checkbox"/>	<input checked="" type="checkbox"/>	<input checked="" type="checkbox"/>	<input checked="" type="checkbox"/>	<input checked="" type="checkbox"/>	<input checked="" type="checkbox"/>
<b>BLADES</b>														
66 Blade (1.68 m)							<input type="checkbox"/>	<input type="checkbox"/>	<input type="checkbox"/>					
72 Blade (1.83 m)	<input type="checkbox"/>	<input type="checkbox"/>	<input type="checkbox"/>	<input type="checkbox"/>	<input type="checkbox"/>	<input type="checkbox"/>				<input type="checkbox"/>				
72 V-Blade (1.83 m)	<input type="checkbox"/>	<input type="checkbox"/>	<input type="checkbox"/>	<input type="checkbox"/>	<input type="checkbox"/>	<input type="checkbox"/>				<input type="checkbox"/>				
72 Hydraulic Blade (1.83 m)												<input type="checkbox"/>	<input type="checkbox"/>	<input type="checkbox"/>
<b>TYRES</b>														
Turf	<input type="checkbox"/>	<input type="checkbox"/>	<input type="checkbox"/>	<input type="checkbox"/>	<input type="checkbox"/>	<input type="checkbox"/>								
Cayman AT (All Terrain)	<input type="checkbox"/>	<input type="checkbox"/>			<input type="checkbox"/>									
Cayman KT (Knobby)	<input type="checkbox"/>				<input type="checkbox"/>									
Cayman XT (Extrem Terrain)		<input type="checkbox"/>												
HPAP (High Performance All Purpose)						<input type="checkbox"/>								
HPAT (Aggressive Tread)						<input type="checkbox"/>								
Terra-Hawk AT (All Terrain)							<input type="checkbox"/>	<input type="checkbox"/>	<input type="checkbox"/>	<input type="checkbox"/>		<input type="checkbox"/>	<input type="checkbox"/>	<input type="checkbox"/>
Maxxis Big Horn 2.0 Radials							<input type="checkbox"/>	<input type="checkbox"/>	<input type="checkbox"/>	<input type="checkbox"/>	<input type="checkbox"/>	<input type="checkbox"/>	<input type="checkbox"/>	<input type="checkbox"/>
Steel 14 rim Maxxis Big Horn Tyre										<input type="checkbox"/>	<input type="checkbox"/>	<input type="checkbox"/>	<input type="checkbox"/>	<input type="checkbox"/>
Camso Tracks**										<input type="checkbox"/>	<input type="checkbox"/>	<input type="checkbox"/>	<input type="checkbox"/>	<input type="checkbox"/>
<b>OTHER ACCESSORIES</b>														
Winch	<input type="checkbox"/>	<input type="checkbox"/>	<input type="checkbox"/>	<input type="checkbox"/>	<input type="checkbox"/>	<input type="checkbox"/>	<input type="checkbox"/>	<input type="checkbox"/>	<input type="checkbox"/>	<input type="checkbox"/>	<input type="checkbox"/>	<input type="checkbox"/>	<input type="checkbox"/>	<input type="checkbox"/>
Back-Up Alarm	<input type="checkbox"/>	<input type="checkbox"/>	<input type="checkbox"/>	<input checked="" type="checkbox"/>	<input type="checkbox"/>	<input type="checkbox"/>	<input type="checkbox"/>	<input type="checkbox"/>	<input type="checkbox"/>	<input type="checkbox"/>	<input type="checkbox"/>	<input type="checkbox"/>	<input type="checkbox"/>	<input type="checkbox"/>
Bucket Holder		<input type="checkbox"/>	<input type="checkbox"/>	<input type="checkbox"/>	<input type="checkbox"/>		<input type="checkbox"/>	<input type="checkbox"/>	<input type="checkbox"/>	<input type="checkbox"/>	<input type="checkbox"/>	<input type="checkbox"/>	<input type="checkbox"/>	<input type="checkbox"/>
High Capacity Alternator Kit (55 Amp)	<input type="checkbox"/>	<input type="checkbox"/>			<input type="checkbox"/>		<input type="checkbox"/>	<input checked="" type="checkbox"/>	<input checked="" type="checkbox"/>	<input checked="" type="checkbox"/>	<input checked="" type="checkbox"/>	<input checked="" type="checkbox"/>	<input checked="" type="checkbox"/>	<input checked="" type="checkbox"/>
Horn Kit	<input type="checkbox"/>	<input type="checkbox"/>	<input type="checkbox"/>	<input type="checkbox"/>	<input type="checkbox"/>	<input checked="" type="checkbox"/>	<input checked="" type="checkbox"/>	<input checked="" type="checkbox"/>	<input checked="" type="checkbox"/>	<input checked="" type="checkbox"/>	<input checked="" type="checkbox"/>	<input checked="" type="checkbox"/>	<input checked="" type="checkbox"/>	<input checked="" type="checkbox"/>
Speedometer							<input type="checkbox"/>							
Seat Cover	<input type="checkbox"/>	<input type="checkbox"/>	<input type="checkbox"/>	<input type="checkbox"/>	<input type="checkbox"/>	<input type="checkbox"/>	<input type="checkbox"/>	<input type="checkbox"/>	<input type="checkbox"/>					

■ Standard    □ Optional    \*Homologation type may vary by country. Please refer to your dealer. / \*\* Not available through Deere & Company. Please contact your local dealer.

## SPECIFICATIONS



	TS	TX	TX TURF
<b>T-SERIES / WORK SERIES</b>			
<b>ENGINE</b>			
Type	401 cc, 1-Cylinder, 4-Cycle Petrol	675 cc / 401 cc, 2-Cylinder / 1-Cylinder, 4-Cycle Petrol	675 cc / 401 cc, 2-Cylinder / 1-Cylinder, 4-Cycle Petrol
Power kW (hp) at min <sup>-1</sup>	7.1 (9.7) at 3300 98 / 67 / EC	12.5 (16.8) at 3200 / 8 (10.9) at 3250 98 / 67 / EC	12.5 (16.8) at 3200 / 8 (10.9) at 3250 98 / 67 / EC
Cooling System	Air	Air	Air
Fuel Tank, ltr	18.9	18.9	18.9
<b>POWER STEERING</b>	NA	NA	NA
<b>4-WHEEL DRIVE</b>	No	No	No
<b>DRIVE SYSTEM</b>			
Type	CVT (Continuously Variable Transmission)	CVT (Continuously Variable Transmission)	CVT (Continuously Variable Transmission)
Ground Speed, km/h*	0–32 Forward	0–32 Forward / 0–25 Forward	0–32 Forward / 0–25 Forward
Differential Lock	Standard, Hand-Operated	Standard, Hand-Operated	Standard, Hand-Operated
Brakes	Wet Disc in Transaxle	All-Wheel Hydraulic Disc	All-Wheel Hydraulic Disc
Suspension, Front	Independent Spring-Over-Shock, Single A-Arm	Independent Spring-Over-Shock, Single A-Arm	Independent Spring-Over-Shock, Single A-Arm
Suspension, Rear	Two High-Flotation Tyres, Low Pressure Tyres (Solid Axle)	Semi-Independent Coil-Over-Shock	Semi-Independent Coil-Over-Shock
Suspension Travel, mm	127 Front	127 Front & 76 Rear	127 Front & 76 Rear
<b>DIMENSIONS</b>			
Dimensions (W × L × H), mm	1525 × 2746 × 1108	1525 × 2847 × 1108 / 1525 × 2847 × 1209	1525 × 2847 × 1108 / 1525 × 2847 × 1209
Weight (Including Fluids), kg	415	508 / 501	508 / 501
Towing Capacity, kg	408	454	454
Payload Capacity, kg	408	454	454
<b>GROUND CLEARANCE</b>	Under Transaxle: 152 Under Foot Platform: 250	Under Transaxle: 145 Under Foot Platform: 270	Under Transaxle: 145 Under Foot Platform: 270
<b>DELUXE CARGO BOX</b>			
Type / Material	16 Gauge Steel	Deluxe (Polypropylene Side Panels and Tailgate; Steel Floor and Load Guard)	Deluxe (Polypropylene Side Panels and Tailgate; Steel Floor and Load Guard)
Dimensions (L × W × D), mm	1003 × 1245 × 229	1143 × 1320 × 305	1143 × 1320 × 305
Volume, ltr	290	460	460
Capacity, kg	227	272	272
<b>TYRES</b>			
Front	22.5 × 10–8, 4 PR Cayman KT (Knobby) 22.5 × 10–8, 4 PR Cayman Turf 22.5 × 10–8, 4 PR Cayman AT (All Terrain)	22 × 9.5–10, 4 PR Cayman AT (All Terrain – Only Available on TX) 22 × 9.5–10, 4 PR Cayman Turf 22 × 9.5–10, 4 PR Cayman XT (Xtreme Terrain – Only Available on TX)	22 × 9.5–10, 4 PR Cayman AT (All Terrain – Only Available on TX) 22 × 9.5–10, 4 PR Cayman Turf 22 × 9.5–10, 4 PR Cayman XT (Xtreme Terrain – Only Available on TX)
Rear	25 × 12–9, 4 PR Cayman KT (Knobby) 25 × 12–9, 4 PR Cayman Turf 25 × 13–9, 4 PR Cayman AT (All Terrain)	24 × 10.5–10, 4 PR Cayman AT (All Terrain – Only Available on TX) 24 × 12–10, 4 PR Cayman Turf 24 × 12–10, 4 PR Cayman XT (Xtreme Terrain – Only Available on TX)	24 × 10.5–10, 4 PR Cayman AT (All Terrain – Only Available on TX) 24 × 12–10, 4 PR Cayman Turf 24 × 12–10, 4 PR Cayman XT (Xtreme Terrain – Only Available on TX)
Colours	Green & Yellow	Green & Yellow	Green & Yellow
Seating Capacity	2	2	2

\* Homologation type and speed may vary by country. Please refer to your dealer.



TE

TH 6X4

HPX815E

## WORK SERIES

48 VDC Separately Exited, Electric	854cc, 3-Cylinder, 4-Cycle, Diesel	854cc, 3-Cylinder, 4-Cycle, Diesel
48 V with 8 Trojan T-145 Batteries	13.6 (18.5) at 3400 ECE-R24	13.6 (18.5) at 3400 ECE-R24
NA	Liquid	Liquid
NA	18.9	20.1
	NA	NA
	Yes	Yes
NA	CVT (Continuously Variable Transmission)	2-speed CVT (Continuously Variable Transmission)
0 – 24 Forward	0 – 32 Forward	0 – 40 Forward
	Standard, Hand-Operated	Auto-Locking (Front) / Positive Locking, Mechanically Actuated-Hand-Operated (Rear)
Dual Rear Wheel Mechanical Drum	Wet Disc in Transaxle	Front / Rear Hydraulic Disc
Independent Spring-Over-Shock, Single A-Arm	Independent Spring-Over-Shock, Single A-Arm	Independent with McPherson Strut
Two High-Flotation Tyres, Low Pressure Tyres (Solid Axle)	Two High-Flotation Tyres, Low Pressure Tyres (Solid Axle)	Coil-Over-Shock
127 Front	127 Front	131 Front & 90 Rear
1525 × 2728 × 1130	1525 × 2754 × 1108	1506 × 2743 × 1867
667w / Batteries	630	693
273	726	590
409	726	635
Under Foot Platform: 185	Under Transaxle: 165 Under Foot Platform: 216	Under Transaxle: 152 Under Foot Platform: 305
Deluxe (Polypropylene Side Panels and Tailgate; Steel Floor and Load Guard)	Deluxe (Polypropylene Side Panels and Tailgate; Steel Floor and Load Guard)	Deluxe (Polypropylene Side Panels and Tailgate; Steel Floor and Load Guard)
1143 × 1320 × 305	1143 × 1320 × 305	1143 × 1320 × 305
460	460	320
227	508	454
22 × 9.5 – 10, 4 PR Cayman Turf	22.5 × 10 – 8, 4 PR Cayman KT (Knobby) 22.5 × 10 – 8, 4 PR Cayman Turf 22.5 × 10 – 8, 4 PR Cayman AT (All Terrain)	24 × 9.5 – 10, 4 PR High Performance All Purpose (HPAP) 24 × 9.5 – 10, 4 PR High Performance All Terrain (HPAT) 24 × 9.5 – 10, 4 PR Turf
24 × 12 – 10, 4 PR Cayman Turf	25 × 12 – 9, 4 PR Cayman KT (Knobby) 25 × 12 – 9, 4 PR Cayman Turf 25 × 13 – 9, 4 PR Cayman AT (All Terrain)	24 × 10.5 – 10, 4 PR High Performance All Purpose (HPAP) 24 × 12 – 10, 4 PR High Performance All Terrain (HPAT) 24 × 12 – 10, 4 PR Turf
Green & Yellow	Green & Yellow	Green & Yellow
2	2	2

## SPECIFICATIONS



	XUV560E	XUV590M	XUV590M S4	XUV855M
<b>XUV-SERIES / CROSS-OVER SERIES</b>				
<b>ENGINE</b>				
Type	570 cc, 4 cycle gas, dynamically turned carb	586 cc, 4 cycle gas, electronic fuel injection (EFI)	586 cc, 4 cycle gas, electronic fuel injection (EFI)	854 cc, 3-Cylinder Diesel
Power kW (hp) at min <sup>-1</sup>	12.1 (16) at 3600 97 / 68 / EC	22.9 (31) at 5200 ECE-R120	22.9 (31) at 5200 ECE-R120	16.1 (21.9) at 3400 ECE-R24
Cooling System	Air	Liquid	Liquid	Liquid
Fuel Tank, ltr	18.5	28	28	27.6
<b>POWER STEERING</b>	No	Standard	Standard	Standard
<b>4-WHEEL DRIVE</b>	Yes	Yes	Yes	Yes
<b>DRIVE SYSTEM</b>				
Type	2-speed CVT (Continuously Variable Transmission) with Clutch Enclosure	2-speed CVT (Continuously Variable Transmission) with Clutch Enclosure	2-speed CVT (Continuously Variable Transmission) with Clutch Enclosure	2-speed CVT (Continuously Variable Transmission) with Enclosed Clutch & Engine Braking
Ground Speed, km/h*	0 – 45 Forward	0 – 60 Forward	0 – 60 Forward	0 – 40 Forward
Differential Lock	Limited Slip (Front) / Positive Locking, Mechanically Actuated – Hand-Operated (Rear)	Limited Slip (Front) / Positive Locking, Mechanically Actuated – Hand-Operated (Rear)	Limited Slip (Front) / Positive Locking, Mechanically Actuated – Hand-Operated (Rear)	Auto-Locking (Front) / Positive Locking, Mechanically Actuated – Hand-Operated (Rear)
Brakes	Front/Rear Hydraulic Disc w/ twin piston calipers and stainless steel rotors	Front/Rear Hydraulic Disc w/ twin piston calipers and stainless steel rotors	Front/Rear Hydraulic Disc w/ twin piston calipers and stainless steel rotors	Front / Rear Hydraulic Disc
Suspension, Front	Independent; double A-arm w/ adjustable coil over shock	Independent; double A-arm w/ adjustable coil over shock	Independent; double A-arm w/ adjustable coil over shock	Fully Independent Dual A-Arm with Adjustable Coils
Suspension, Rear	Independent; lower H-arm and upper camber link w/ adjustable coil cover shocks	Independent; lower H-arm and upper camber link w/ adjustable coil cover shocks	Independent; lower H-arm and upper camber link w/ adjustable coil cover shocks	Fully Independent Dual A-Arm with Adjustable Coils & Sway Bar
Suspension Travel, mm	203 Front & 203 Rear	203 Front & 203 Rear	203 Front & 203 Rear	203 Front & 229 Rear
<b>DIMENSIONS</b>				
Dimensions (W × L × H), mm	1435 × 2921 × 1867	1435 × 2870 × 1867	1435 × 3658 × 1880	1571 × 3021 × 1903
Weight (Including Fluids), kg	635	650	746	788
Towing Capacity, kg	499	499	499	680
Payload Capacity, kg	363	395	490	635
<b>GROUND CLEARANCE</b>	Under Transaxle: 267 Under Foot Platform: 267	Under Transaxle: 267 Under Foot Platform: 267	Under Transaxle: 236 Under Foot Platform: 236	Under Transaxle: 267 Under Foot Platform: 311
<b>DELUXE CARGO BOX</b>				
Type / Material	High-Density Polyethylene Copolymer Composite	High-Density Polyethylene Copolymer Composite	High-Density Polyethylene Copolymer Composite	Deluxe (Polypropylene Side Panels and Tailgate; Steel Floor and Load Guard)
Dimensions (L × W × D), mm	820 × 1209 × 297	820 × 1209 × 297	820 × 1209 × 297	1143 × 1320 × 305
Volume, ltr	250	250	250 (up to 370 with Convertible Cargo Rack)	460
Capacity, kg	181	227	160	454
<b>TYRES</b>				
Front	26 × 8 – 14 Maxxis Big Horn 2.0, Radial 25 × 8 – 12 Terrahawk AT (All Terrain)	26 × 8 – 14 Maxxis Big Horn 2.0, Radial 25 × 8 – 12 Terrahawk AT (All Terrain)	26 × 8 – 14 Maxxis Big Horn 2.0, Radial 25 × 8 – 12 Terrahawk AT (All Terrain)	25 × 9.00 – 12, 4 PR Terrahawk AT 27 × 9.00 – 14, 6 PR Big Horn Maxxis XT
Rear	26 × 10 – 14 Maxxis Big Horn 2.0, Radial 25 × 10 – 12 Terrahawk AT (All Terrain)	26 × 10 – 14 Maxxis Big Horn 2.0, Radial 25 × 10 – 12 Terrahawk AT (All Terrain)	26 × 10 – 14 Maxxis Big Horn 2.0, Radial 25 × 10 – 12 Terrahawk AT (All Terrain)	25 × 11.00 – 12, 4 PR Terrahawk AT 27 × 11.00 – 14, 6 PR Big Horn Maxxis XT
Colours	Green & Yellow	Green & Yellow	Green & Yellow	Green & Yellow
Seating Capacity	2	2	4	2

\* Homologation type and speed may vary by country. Please refer to your dealer.



XUV855M S4

XUV835M

XUV865M

XUV865R

854 cc, 3-Cylinder Diesel

812 cc, 4-cycle gas, Electronic Fuel Injection (EFI)

854 cc, 4-cycle diesel

854 cc, 4-cycle diesel

16.1 (21.9) at 3400 ECE-R24

39.3 (53.4) at 6000 ECE-R120

15.5 (22.8) at 3600 ECER-120

15.5 (22.8) at 3600 ECER-120

Liquid

Liquid

Liquid

Liquid

27.6

42.8

42.8

42.8

Standard

Standard

Standard

Standard

Yes

Yes

Yes

Yes

2-speed CVT (Continuously Variable Transmission) with Enclosed Clutch &amp; Engine Braking

2-speed CVT (Continuously Variable Transmission) with clutch enclosure, oil bath

2-speed CVT (Continuously Variable Transmission) with clutch enclosure, oil bath

2-speed CVT (Continuously Variable Transmission) with clutch enclosure, oil bath

0–51 Forward

0–60 Forward

0–50 Forward

0–50 Forward

Auto-Locking (Front) / Positive Locking, Mechanically Actuated – Hand-Operated (Rear)

Positive locking, mechanically actuated (hand-operated)

Positive locking, mechanically actuated (hand-operated)

Positive locking, mechanically actuated (hand-operated)

Front/Rear Hydraulic Disc

Front/rear hydraulic disc with twin piston front calipers

Front/rear hydraulic disc with twin piston front calipers

Front/rear hydraulic disc with twin piston front calipers

Fully Independent Dual A-Arm with Adjustable Coils

Fully independent dual A-Arm with adjustable coils

Fully independent dual A-Arm with adjustable coils

Fully independent dual A-Arm with adjustable coils

Fully Independent Dual A-Arm with Adjustable Coils &amp; Sway Bar

Fully independent dual A-Arm with adjustable coils and sway bar

Fully independent dual A-Arm with adjustable coils and sway bar

Fully independent dual A-Arm with adjustable coils and sway bar

203 Front &amp; 229 Rear

200.7 Front &amp; 231.14 Rear

200.7 Front &amp; 231.14 Rear

200.7 Front &amp; 231.14 Rear

1571 × 3911 × 1903

1763 × 3228 × 1987

1763 × 3228 × 1987

1763 × 3228 × 1987

946

942 (open station)  
1003 (cab)949 (open station)  
1011 (cab)949 (open station)  
1011 (cab)

680

900

900

900

635

680

680

680

Under Transaxle: 267  
Under Foot Platform: 311

284

284

284

Deluxe (Polypropylene Side Panels and Tailgate; Steel Floor and Load Guard)

Deluxe (Polypropylene Side Panels and Tailgate; Steel Floor and Load Guard)

Deluxe (Polypropylene Side Panels and Tailgate; Steel Floor and Load Guard)

Deluxe (Polypropylene Side Panels and Tailgate; Steel Floor and Load Guard)

1143 × 1320 × 305

1143 × 1320 × 304.8

1143 × 1320 × 304.8

1143 × 1320 × 304.8

460

460

460

460

454

454

454

454

27 × 9.00 – 14, 6 PR Big Horn Maxxis XT

25 × 9 – 12 Terrahawk AT (All Terrain)  
27 × 9 – R14 Maxxis Big Horn Radials (Extreme Terrain)25 × 9 – 12 Terrahawk AT (All Terrain)  
27 × 9 – R14 Maxxis Big Horn Radials (Extreme Terrain)25 × 9 – 12 Terrahawk AT (All Terrain)  
27 × 9 – R14 Maxxis Big Horn Radials (Extreme Terrain)

27 × 11.00 – 14, 6PR Big Horn Maxxis XT

25 × 11 – 12 Terrahawk AT (all terrain)  
27 × 11 – R14 Maxxis Big Horn Radials (Extreme Terrain)25 × 11 – 12 Terrahawk AT (all terrain)  
27 × 11 – R14 Maxxis Big Horn Radials (Extreme Terrain)25 × 11 – 12 Terrahawk AT (all terrain)  
27 × 11 – R14 Maxxis Big Horn Radials (Extreme Terrain)

Olive &amp; Black

Green & Yellow, Camouflage,  
Olive & BlackGreen & Yellow, Camouflage,  
Olive & Black

Green &amp; Yellow

4

3 (offroad only, 2 seats onroad)

3 (offroad only, 2 seats onroad)

3 (offroad only, 2 seats onroad)

# RIDE IN STYLE WITH JOHN DEERE MERCHANDISE

FROM STYLISH WORKWEAR AND PRACTICAL ACCESSORIES TO GIFTS AND TOYS, YOUR DEALER HAS A WIDE RANGE OF JOHN DEERE MERCHANDISE WAITING FOR YOU IN STORE. DROP BY SOON!



This literature has been compiled for worldwide circulation. While general information, pictures and descriptions are provided, some illustrations and text may include finance, credit, insurance, product options and accessories not available in all regions. Please contact your local dealer for details. John Deere reserves the right to change specification and design of products described in this literature without notice. The green and yellow colour scheme, the leaping deer logo and the JOHN DEERE word mark are trademarks of Deere & Company.